

Andrew O'Malley

Miscellaneous Projects

B. Eng., Electrical Engineering
Ryerson Polytechnic University
aomalley@ieee.org
(905) 728-9909

Copyright Andrew O'Malley, 2001

Contents

- 2 4-Bit Microprocessor
- 3 Theatre “Fire” Effect

4-Bit Microprocessor

Challenge:

Build a programmable processor module to demonstrate various micro-computer attributes.

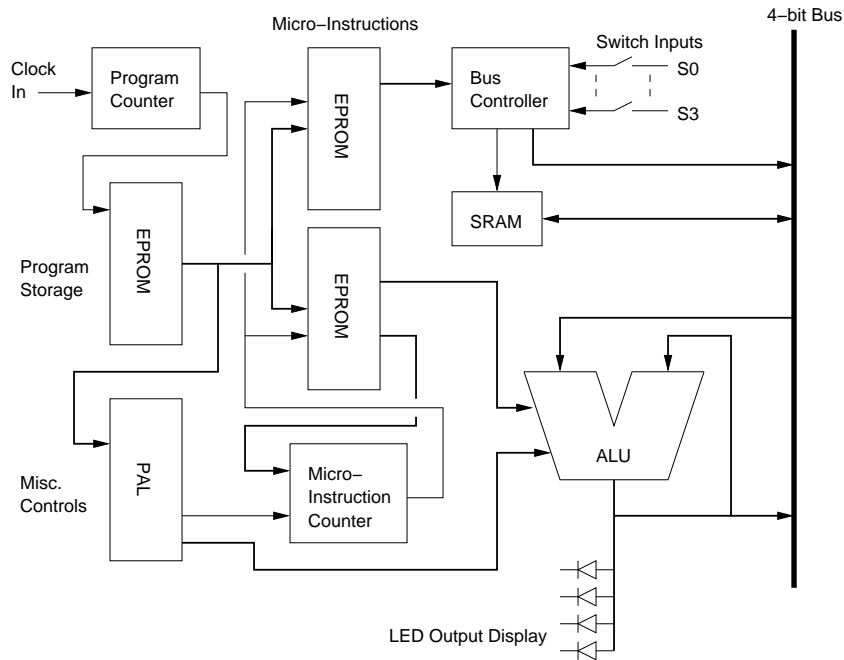

Solution:

Programmable devices store programs and micro-instructions, interfaced with a functional data path comprised of readily available logic devices (PC, ALU, Bus Controller, etc.). Simple user interface provided via toggle switches and LEDs.

Results:

4-bit processor capable of storing and executing simple 16-step programs demonstrating data input, output, manipulation, and storage.

Theatre “Fire” Effect

Challenge:

A theatre effect for a small fire in a bucket.

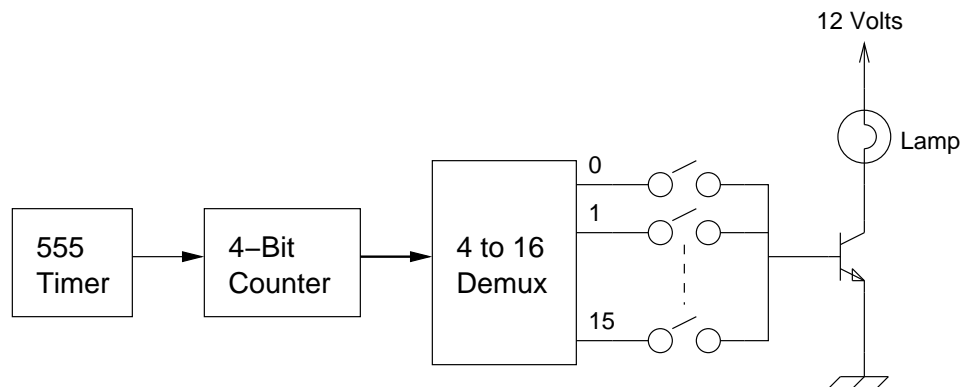

Solution:

Simple digital circuit creates 16-step sequence that can be “programmed” with switches for “random” lamp flicker.

Result:

Constructed by theatre technician with easily obtained components and used successfully in student stage production.